

BOMAG

TANDEM VIBRATORY ROLLERS BW 100 AD-3, BW 120 AD-3

PERFORMANCE DATA

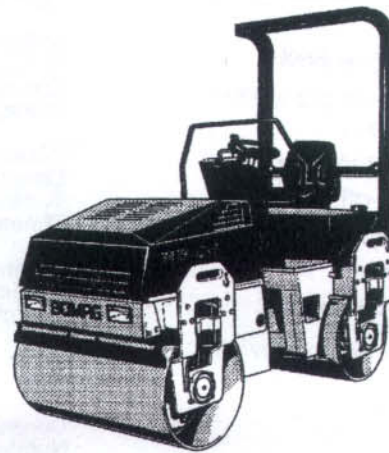

Machine type	Compaction output (m ³ /h) at recommended soil layer thicknesses		
	Gravel, sand	mixed soil	Silt, clay
BW 100 AD-3	80-145	55-105	38-73
BW 120 AD-3	85-170	65-125	43-85

Machine type	Compaction output (t/h) at different asphalt layer thicknesses		
	2-4 cm	6-8 cm	10-12 cm
BW 100 AD-3	15-40	40-60	60-100
BW 120 AD-3	20-45	40-70	70-120

BOMAG

TECHNICAL DATA

Standard Equipment

- Hydrostatic drive
- Hydrostatic vibration drive
- Hydrostatic articulated steering
- Vibration control in travel lever
- 2 scrapers per drum
- Seat adjustable for weight
- Plastic water tank
- Gravity water sprinkler system
- Warning indicator lights
- Hour meter
- Lockable anti vandal dashboard protection
- Lockable engine cover
- Transport lashing and lifting points front/rear
- Emergency stop button
- Vibration cut-off, rear drum
- Corrosion and weather protected ignition switch
- ROPS with safety belt
- Seat contact safety device

Optional Equipment

- ♦ High spec. package inc. dual frequency, high speed and work lights ♦
- Folding ROPS
- ROPS cab
- Road traffic regulation lights
- Asphalt edge cutter
- Flashing beacon
- Back-up alarm
- Pressure sprinkler system
- Special paint
- Tool kit

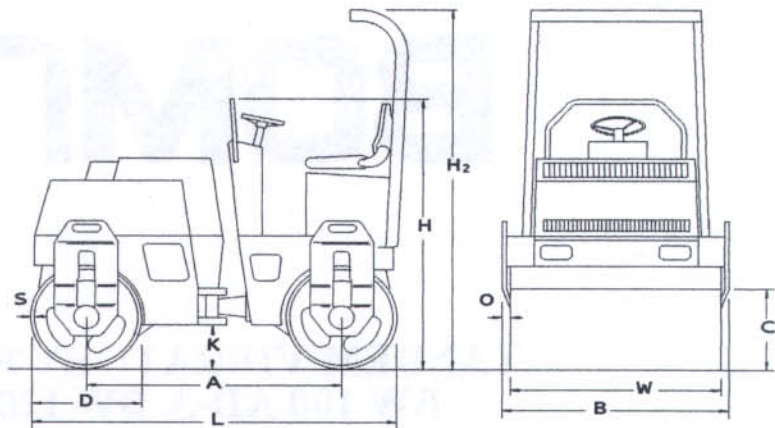

Dimensions in mm											
	A	B	C	D	H	H ₂	K	L	O	S	W
BW 100 AD-3	1725	1076	555	700	1800	2465	235	2425	38	13	1000
BW 120 AD-3	1725	1276	555	700	1800	2465	235	2425	38	13	1200

Technical data

Weights

Operating weight CECE..... kg	2400	2630
Operating weight with ROPS..... kg	2470	2700
Average static linear load CECE..... kg/m	1240	1130

BOMAG BW100AD-3

BOMAG BW120AD-3

Dimensions

Length with ROPS.....mm	2475	2475
Turning radius, inner..... mm	2720	2620
Dimensions.....	see sketch	see sketch

Driving Characteristics (depending on site conditions)

Speed (option*).....kph	0-8.5 (0-10)	0-8.5 (0-10)
Max.gradeability without/with vib..... %	40/30	40/30

Drive

Engine.....	Deutz	Deutz
Type.....	F2L 1011 F	F2L 1011 F
Cooling.....	Air	Air
Number of Cylinders.....	2	2
Performance ISO 9249 (option*)... kW	19.5 (22)	19.5 (22)
Speed (option*).....rpm	2500(3000)	2500(3000)
Electric equipment.....V	12	12
Drive system.....	hydrostatic	hydrostatic
Driven drum.....	front/rear	front/rear

Brakes

Service brake.....	hydrostatic	hydrostatic
Parking brake.....	hydromech	hydromech

Steering

Steering system.....	oscill./artic.	oscill./artic.
Steering method.....	hydrostatic	hydrostatic
Steering angle +/-.....degrees	30	30
Oscillating angle +/-.....degrees	12	12

Vibratory system

Vibrating drum.....	front/rear	front/rear
Drive system.....	hydrostatic	hydrostatic
Frequency (option*)..... Hz	55 (55/66)	55 (55/66)
Amplitude.....mm	0.53	0.53
Centrifugal force/drum (option*)..... kN	23(24)	29(29)

Sprinkler system

Type	gravity	gravity
------------	---------	---------

Capacities

Fuel.....lt	35	35
Water.....lt	180	180

Technical data subject to change without notice. Illustrations may show optional equipment.

BOMAG (Great Britain) Ltd.

Sheldon Way
Larkfield Aylesford
Kent ME20 6SE
Telephone 01622 716611
Fax 01622 718385

BOMAG